

PITUMEC

THE PCON 660 CONCENTRIC UNDERREAMING SYSTEM

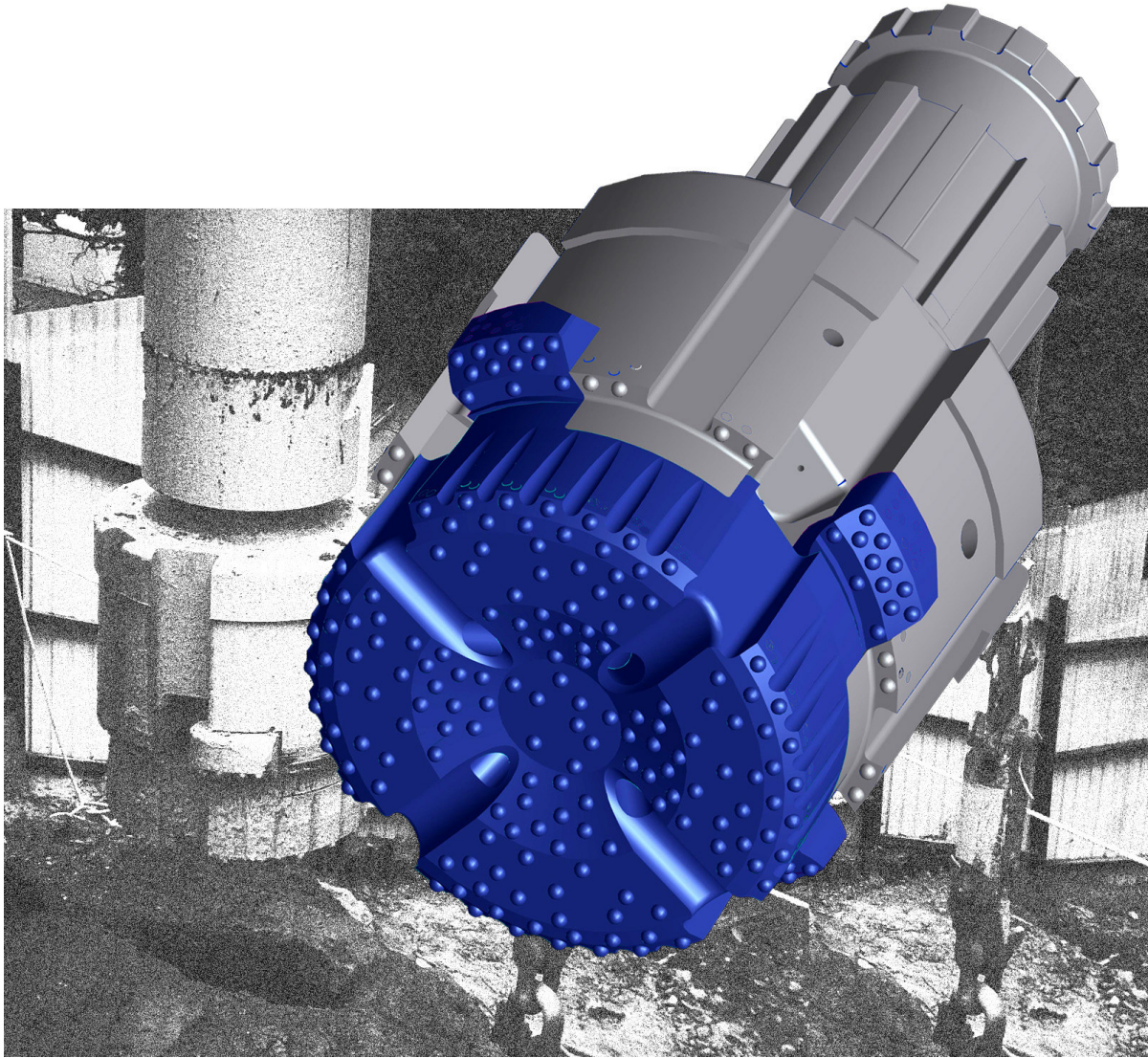

CASING SIZE 711MM OD X 685MM ID DRILLING DIA. 735MM

PNEUMEC PCON 660 CONCENTRIC UNDERREAMING SYSTEM

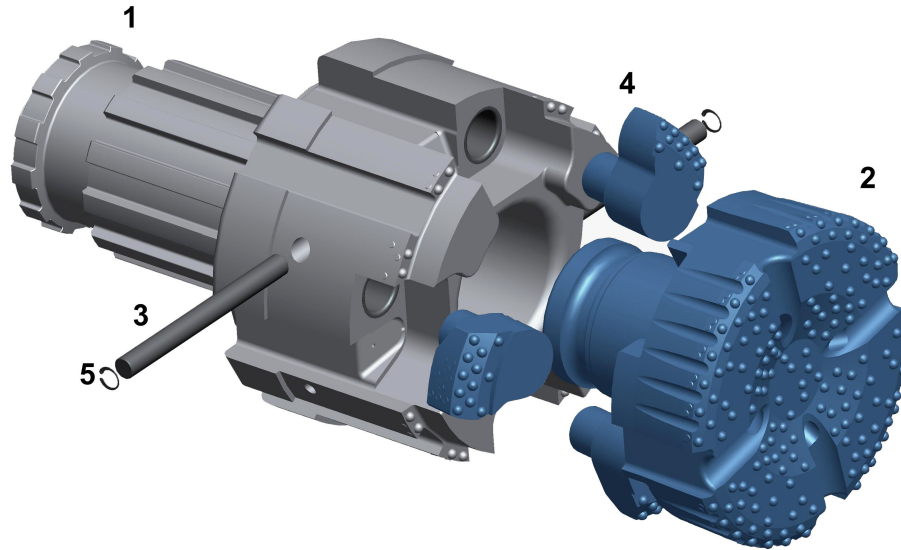

PCON 660 PARTS LIST

1.	GUIDE DEVICE N240 SHANK	UGD660N24PCN
2.	PILOT BIT	UPB660PCN
3.	LOCKING PIN (2)	USP66050PCN
4.	REAMER (4)	UBS660PCN
5.	CIRCLIP (2)	USP66053PCN
6.	COMPLETE SYSTEM N240 SHANK	UCS660N24PCN

PCON 660 SPECIFICATIONS

UPPER BODY DIAMETER	681MM	CLOSED DIAMETER	656MM
REAMING DIAMETER	735MM	CASING SIZE	711MM OD X 685MM ID
SYSTEM LENGTH	1207MM	SYSTEM WEIGHT	1770KG

PCON 660 CASING SHOES

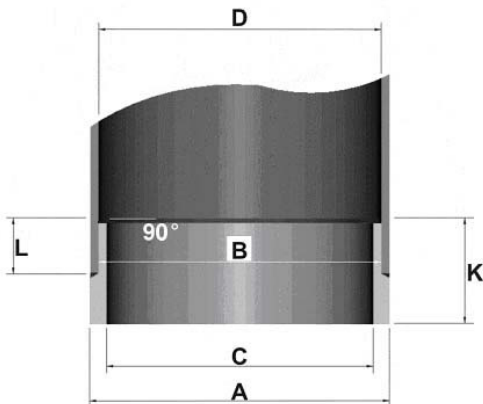

DIA. A	711MM
DIA. B	683.5MM
DIA. C	661.5MM
DIA. D	685MM
L	105MM
K	195MM

PNEUMEC

PNEUMEC COMPANY LIMITED

1st Floor, Tin On Sing Comm. Bldg., 41-43 Graham St. Central, H.K.

Tel : (852) 2180 9922

Fax : (852) 2180 9982

Website : www.pneumec.com

email : info@pneumec.com